



## **Customised Interface Pillar**

### **ESB Ecar Interface Pillar – Complete Electrical Unit**



**Code: 9056**

*Contact Sales +353 1 8254007 or +353 87 6756927 to confirm current design specification*

## Customised Security Kiosks

### Secure Enclosure 600W X 900H X 280D + 250H Plinth

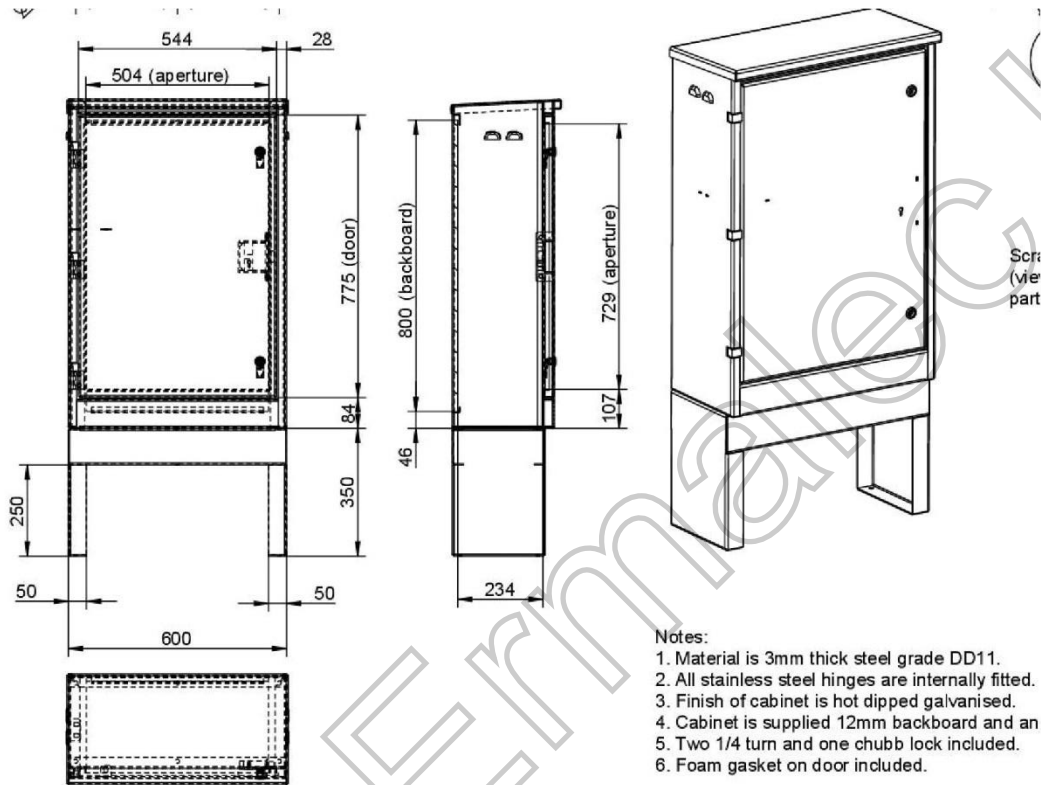

Scr:  
(vie  
part



**Code: 9092**

Contact Sales +353 1 8254007 or +353 87 6756927 to confirm current design specification



## **Customised Substation Kiosk**

**Galvanised 3 door Kiosk 3500W X 1600D X 2200H**

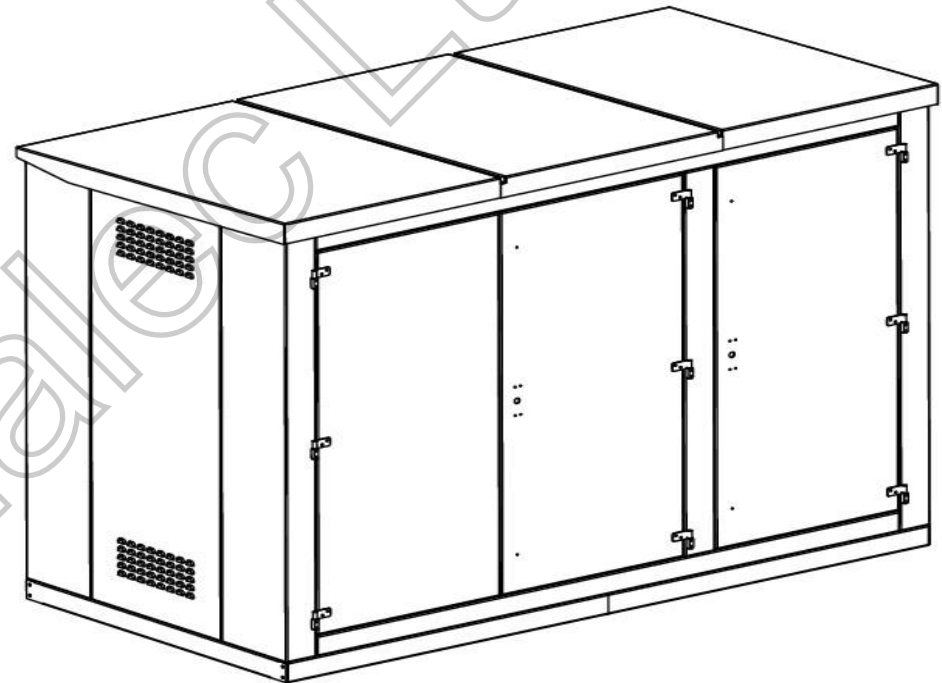

**Code: 9108**

*Contact Sales +353 1 8254007 or +353 87 6756927 to confirm current design specification*



**Actuator Covers**

**Outline dims: 800W X 800D X 1220H**

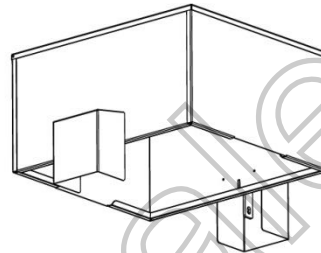
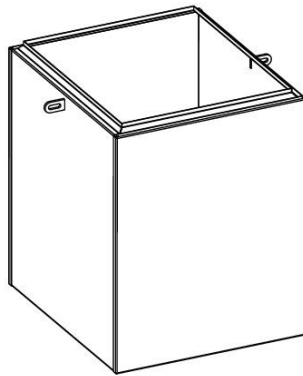

**Cover & Base for housing of Actuator Unit**

**Code: 9106**



## Customised Security Kiosks

### Secure Enclosure 650W X 1000H X 300D + 250H Plinth

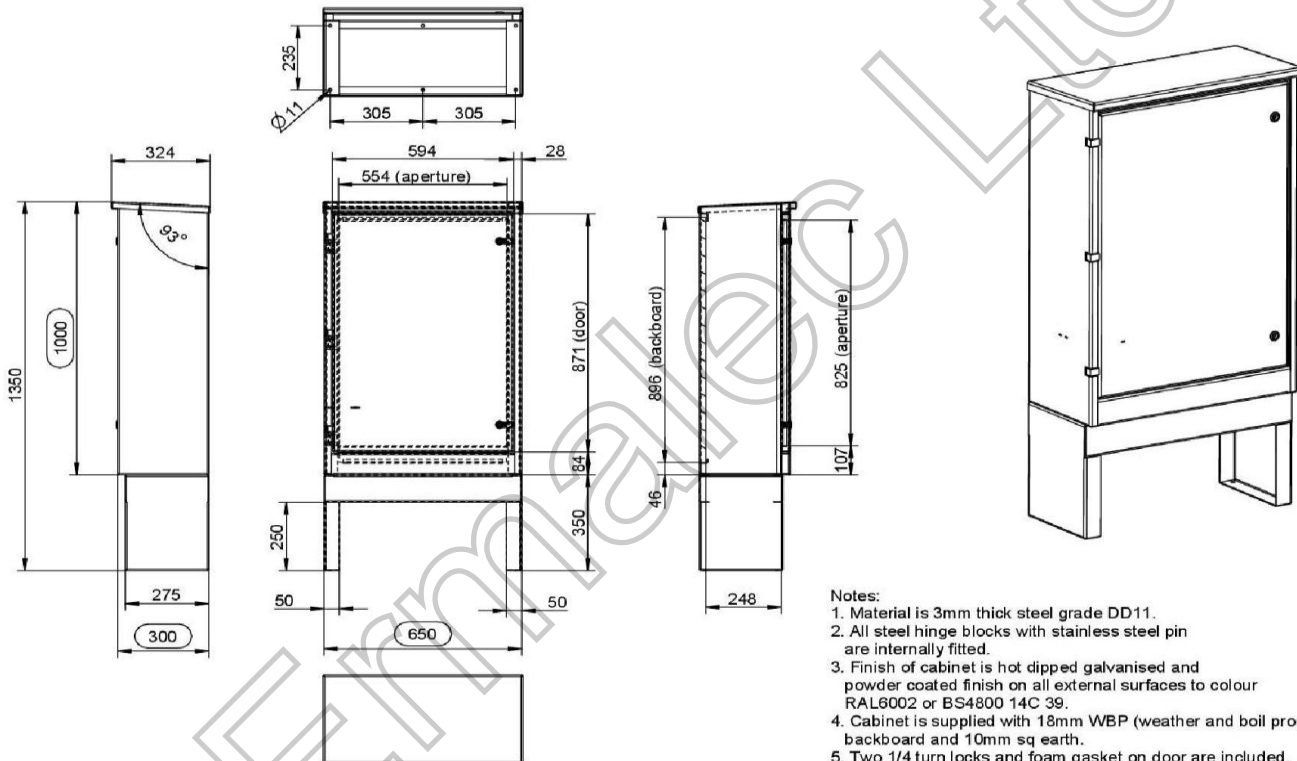

- Notes:
1. Material is 3mm thick steel grade DD11.
  2. All steel hinge blocks with stainless steel pin are internally fitted.
  3. Finish of cabinet is hot dipped galvanised and powder coated finish on all external surfaces to colour RAL6002 or BS4800 14C 39.
  4. Cabinet is supplied with 18mm WBP (weather and boil proof) backboard and 10mm sq earth.
  5. Two 1/4 turn locks and foam gasket on door are included.

**Code: 9122**